

THE GOLDEN YEARS

The El Dorado Senior Center Monthly Newsletter



MARCH POTLUCK PARTY!

Hello, friends! Join us for our next delicious potluck dinner, where good food meets great company! This month, we're excited to welcome Tiya Tonn, Executive Director of the Butler County Historical Society/Kansas Oil Museum, who will share the latest updates on our community's rich history.

Date: Monday, March 3rd

Time: 6:00 PM

Main Course: Sloppy Joes

Guest: Tiya Tonn, Executive Director of the Butler County Historical Society/Kansas Oil Museum

Sponsor: Don's Heating & Air 

Did you know the museum sits on 10 acres of history and recently added an Energy Education Center and a STEM Interactive Education Wall? What's next for this treasure trove of local heritage? Tiya has the scoop!

As always, we'll have our 50/50 raffle and a door prize drawing—because who doesn't love a little extra excitement with their meal?

Mark your calendar, bring a dish to share, and join us for a great evening of food, friends, and fascinating history!

**210 EAST SECOND AVE.
EL DORADO, KS
67042**

**PH: 316-321-0142
FX: 316-321-1525**

KTRAINA@ELDOKS.COM

**OFFICE HOURS:
M/W/F: 9:00 A.M. - 5:00 P.M.
T/TH: 9:00 A.M. - 3:00 P.M.**

2025 BOARD & STAFF

**PRESIDENT: ROXANN COOL
VICE PRESIDENT: MARY MAYS
TREASURER: JUDY PARKS
SECRETARY: JANET SPENCER
MEMBER AT LARGE: SUZIE CAWTHORN
MEMBER AT LARGE: JOE HUNTER
MEMBER AT LARGE: SUSAN JOHNSON
MEMBER AT LARGE: MARK SOMERVILLE
MEMBER AT LARGE: BARBARA HIGGINS**

**DIRECTOR - KRISTINA TRAINA
KITCHEN - JAMES SCOTT**

**FOLLOW US ON OUR NEW
FACEBOOK PAGE.
EL DORADO SENIOR CENTER**





HAPPY BIRTHDAY TO OUR WONDERFUL SENIORS!



Another year older, another year wiser! Let's celebrate the birthdays of all our amazing seniors. Whether you're celebrating a milestone or just another year of life, you deserve to feel special. Remember, age is just a number, and life is a journey to be enjoyed. So, let's make this year's birthdays extra special with lots of love, laughter, and good company!

- | | | | |
|----------------|-----------------|-----------------|-----------------|
| Chauncey Biby | Karla Duran | ShawnTia Harris | Patrick Riggle |
| Algene Clutter | Tom Farley | Tomi Jensen | Dana Shaft |
| Harold Cooper | Lenora Gillett | Marsha Kane | Rex Short |
| Mary Delmez | Sandy Greenwood | Wayne Kavanaugh | Pam Smith |
| Susan Dennis | Diana Griffith | Mary Mays | Jeanette Snyder |
| | | | Ann Templeton |

You know you're getting old when you go to an antique auction and three people bid on you.

Today is your birthday, so congratulate yourself—especially if you're still young enough to remember it.

"We could certainly slow the aging process down if it had to work its way through Congress." —Will Rogers

WELCOME TO THE CLUB!

We're thrilled to welcome our newest members to the El Dorado Senior Center! Every new face brings fresh stories, laughter, and the opportunity to make lifelong friends. Whether you're joining us for lunch, activities, or just great company, we're excited to have you in our vibrant community.

Check out the newest additions to our family below, and be sure to say hello when you see them around!

- | | | |
|----------------|----------------------|----------------|
| Jim Carroll | Marlene Harvey | Burt Long Jr. |
| Wayne Derby | Kenneth (Ken) Harvey | Margaret Paras |
| Luci Florey | Malia Hodgens | Lindy Wilson |
| Mary E. Graves | Ronda Holt | Kay Zang |

MONTHLY TIP: March -

Take advantage of the milder weather by getting outside for regular walks or light outdoor activities, while remembering to stay hydrated and wear sunscreen to protect against the increasing sunlight; this is a great time to start transitioning to more outdoor activities as the weather warms up.

THE BUZZ

CELEBRATING EUDORA SHELDON'S DEDICATION TO TAI CHI

After nearly 10 years of volunteering her time and expertise, Eudora Sheldon is retiring from leading our Thursday morning Tai Chi class. We are so grateful for her dedication and encourage everyone to thank her for her service. Tai Chi will continue at the same time—**Thursdays at 9:30 AM**—now as a video-led class. We hope you'll join us!

SAVE THE DATE: SPRING FLING SENIOR RESOURCE FAIR

Join us on **Wednesday, April 30, 2025, from 9:00 AM to 2:00 PM** for the largest senior-focused event in Butler County! With over 100 booths at the Butler County Community Building and the Civic Center in El Dorado, this is a great opportunity to explore resources, connect with organizations, and gather valuable information. A handicap-accessible shuttle will run from the Senior Center for easy access.

We'll have a booth at the fair and need volunteers to help at our table. If you're interested, please contact the office. We'd love your help!

GET READY TO DANCE THE NIGHT AWAY!

Mark your calendars because The Chuck Haukos Band is coming to the El Dorado Senior Center on **Friday, March 21st at 6:30 PM!** For just a \$5 entry fee, you'll enjoy a fantastic evening of live music, good company, and plenty of toe-tapping fun.



Whether you're catching up with old friends or making new ones, it's sure to be a night to remember. So grab your dancing shoes and join us for an evening filled with great tunes and even better company!

STAY SAFE & STEADY!

Mark your calendars! SERC Physical Therapy will be at the Senior Center on Tuesday, March 25th at 11:30 A.M. for a Fall Prevention Presentation. Learn practical tips and simple exercises to help you stay safe and steady on your feet.



Enjoy a delicious lunch while gaining valuable knowledge to keep you active and independent. Don't miss this great opportunity—see you there!

My parents didn't want to move to Florida, but they turned 60 and that's the law. — Jerry Seinfeld

Q: What's the best way to get a man to remember your anniversary?

A: Get married on his birthday

Stop thinking of them as "hot flashes." Think of them as your inner child playing with matches.

Retirement is what happens between doctors' appointments.



THE BUZZ



IMPORTANT NOTICE: MEMBERSHIP MEETING

Mark your calendars! Our Semi-Annual Membership Meeting is set for **Thursday, March 20th at 6:00 PM**, and we want you to be there!

This is an important night where current members will have the opportunity to vote on agenda items and be a part of shaping the future of the center. Plus, we've got a delicious dinner planned—fried chicken, potato salad, baked beans, and a roll—because good food makes every meeting better!

And that's not all! We're thrilled to welcome The Treblemakers, a talented men's singing group, for a special performance. Thank you to TrueCare Pharmacy for sponsoring this event!

This is a great night for friends, fellowship, and fun, so don't miss out! Remember, you must be a current member to attend. See you there!

HOP INTO MARCH WITH A FUN CRAFT!

Get ready to get crafty! March's Craft of the Month is Glass Bowl Bunnies—the perfect way to add a little springtime charm to your home.

Join us on **Monday, March 10th at 9:30 AM** in the craft room for a fun and creative morning. No experience needed—just bring your enthusiasm, and we'll provide the supplies!

Come craft, chat, and create something adorable with friends. We can't wait to see you there!

PAINTING WITH SHEILA IS BACK! 🎨

Grab your brushes and get ready—Painting with Sheila is making a comeback! For just \$5, you can create a beautiful painting and enjoy a fun afternoon of creativity.

When? Monday, March 10th at 2:00 PM

Where? North Side of Senior Center

Cost? Only \$5!



Seating is limited, so don't wait! Sign up and pay in the office ASAP to secure your spot. Let's paint, laugh, and make something beautiful together!



BINGO FUN WITH BEN & FRIENDS!

Get ready for a Bingo day like no other! On **Tuesday, March 11, at 11:30 AM**, Ben from American Senior Benefits and his team will be here with fantastic prizes and their best Bingo-calling voices!

Join us for a fun-filled event, great company, and plenty of chances to win. Bring your friends, your lucky charms, and get ready to shout BINGO!

Time to Renew Your Membership! 📅

For just \$10, swing by the office and renew your membership to stay in the loop with all the perks! Plus, you'll get a snazzy new membership card featuring our brand-new logo. Members enjoy benefits that non-members only dream about—so don't miss out! Renew today and keep the good times rolling!

THE BUZZ



ST. PATRICK'S BREAKFAST – START YOUR DAY THE LUCKY WAY!

Rise and shine, and join us for a delicious St. Patrick's Day Breakfast on Monday, March 17th from 8:00-9:00 AM! We'll be serving up a warm and hearty breakfast casserole, fresh fruit, juice, and coffee—all for just \$5!

We're also looking for a few helpful leprechauns to volunteer! If you'd like to lend a hand, stop by the office to sign up. Let's make this a morning full of good food and great company!

MONTERREY DAY – A TASTY TRADITION!

It's back and as delicious as ever! Monterrey Day is held on the third Monday of every month at 11:30 AM, and for just \$8, you get a plate full of cheesy, saucy goodness!

We kindly ask that you sign up in the office, kitchen, or give us a call so we know how much food to prepare. Carry-out is available, too! This is a great way to enjoy an amazing meal while supporting our center. Don't miss out!

VOLUNTEERS NEEDED – WE NEED YOU!

Want to make a difference at the Senior Center? We are always looking for dedicated, fun, and energetic volunteers to help us thrive! Right now, we need volunteers for our:

- ✓ Event Committee – Help plan and organize fun activities!
- ✓ Fundraising Committee – Support fundraising efforts to keep our center going!
- ✓ Decorations Committee – Bring your creativity and make our events extra special!

If you're interested, stop by the office or kitchen to learn more. Our center runs on volunteers, and we'd love to have you be part of the team!

QUILT GUILD – STITCHING TOGETHER COMMUNITY!



Love quilting? Our Quilt Guild meets every second Thursday at 6:00 PM right here at the Senior Center! New to the group? Visitors are welcome to attend twice before deciding to become a member. Membership is just \$20 per year!

And don't forget about Sew Saturday—a casual day to work on projects, get help if you're stuck, and enjoy some great company! Sew Saturday is now open to everyone!

NEW! LUNCH & LEARN SERIES

We're excited to launch our Lunch & Learn series this month, and our first guest will be the Butler County Sheriff's Office! They'll be here on **Friday, March 14th at 11:30 AM** for an informative Scam Awareness Presentation, complete with a breathtaking PowerPoint and a special guest!



They'll even be staying for lunch with us, so don't miss this chance to learn, ask questions, and enjoy a meal together. See you there!

THE BUZZ



BOARD MEETING HIGHLIGHTS: TRANSPARENCY FOR OUR MEMBERS

February 2025 Board Meeting Highlights

Approval & Reports:

- January 15, 2025, board meeting minutes approved as written.
- Treasurer's Report for January tabled until March.

Director's Report:

- Membership: 17 new members; 224 renewals; Total: 241.
- Grants: Applied for \$15,000 (HFS) and \$750 (Elks) for "Veterans Corner."
- Donations: Don's Heating & Air - \$150, True Care Pharmacy - \$200.

Activities & Programs:

- Kansas Day (Jan 29): 67 meals served (\$233).
- KS Veteran Services (Feb 11): 53 meals served (\$245); 16 veterans met with reps.
- Upcoming:
 - March 11: Ben Brown (American Senior Benefits).
 - March 18: Larry Burton (Silver Hair Legislature).
 - March 25: Fall Prevention Seminar (SERC Physical Therapy).
 - New: "Lunch 'N Learn" Fridays begin March 14 with Butler County Sheriff's Office.

Fundraisers:

- Past Events:
 - Jan 27 Monterrey Dinner: \$236 raised.
 - Feb 3 Potluck: \$99 donations + \$39 (50/50).
 - Feb 17 Monterrey Dinner: \$436 raised.
- Upcoming:
 - St. Patrick's Day Breakfast (March 17) - Need volunteers.

Upcoming Events:

- Feb 21: Monthly Dance - "Down Every Road."
- March 3 Potluck: Sloppy Joes, Butler County Oil Museum speaker.
- March 20 Membership Meeting: Fried Chicken, Treblemakers performing.

Center & Member Updates:

- Facility & Operations:
 - Renewed Kansas food license (\$250).
- Weather Closures: Center closed Feb 12, 18-20 per new winter policy.
- Concerns Addressed:
 - Addressed evening Bunco group security concerns.
 - Clarified Prairie Port Seniors' trash disposal policy.

Old Business:

- Kitchen Door Update: Installation scheduled for early March.
- Hermes Contract Update: Services now every other month, twice per visit.
- Spring Fling: Center will have a table; volunteers needed.

New Business:

- Front Entrance Repair: City to address in spring.
- Custodial Payroll: Tax filing responsibilities under review.
- Committee Selections:
 - Fundraising: Barbara Higgins (lead), Roxann Cool, Janet Spencer.
 - Events: Mary Mays (lead), Susan Johnson, Judy Parks.
 - Decorations: Suzie Cawthorn (lead), Joe Hunter, Judy Parks.
 - All committees seeking additional volunteers!

Thank you for your continued support of the Senior Center!

MARCH LUNCH MENU

MONDAY - FRIDAY

11:30 A.M.

\$5 SUGGESTED DONATION

PICK-UP MEALS AVAILABLE!

**Menu Subject to Change Without Notice*



**Tired of the same old lunch?
Join us for fresh, homemade
meals made with love!
Call (316) 321-0142 to place
your order at least one day
in advance.**

Monday	Tuesday	Wednesday	Thursday	Friday
<p>3</p>  <p>Spaghetti Garden Salad</p>	<p>4</p> <p>Chicken Fried Steak Mashed Potatoes/Gravy Buttered Corn</p>	<p>5</p> <p>Vegetable Beef Soup Roll</p>	<p>6</p> <p>Roasted Pork Baked Potato Buttered Peas</p>	<p>7</p> <p>Catfish Fillet Waffle Fries Coleslaw</p>
<p>10</p> <p>Cream of Potato & Leek Soup</p>	<p>11</p> <p>Lasagna Garden Salad Garlic Toast</p>	<p>12</p> <p>Hamburgers Steak Fries</p>	<p>13</p> <p>Tomato Basil Soup Toasted Ham & Grilled Cheese</p>	<p>14</p> <p>BBQ Meatballs Scalloped Potatoes</p>
<p>17</p> <p>St. Patty's Breakfast FUNDRAISER 8-9 A.M \$5 MONTERREY FUNDRAISER 11:30 A.M \$8</p> 	<p>18</p> <p>Chicken Alfredo Garden Salad</p>	<p>19</p> <p>Chicken Strips Waffles Mixed Fruit</p>	<p>20</p> <p>Chili Cinnamon Rolls</p>	<p>21</p> <p>Baked White Fish Baked Potato Broccoli Normandy</p>
<p>24</p> <p>Hamburger Rice Casserole Croissants Applesauce</p>	<p>25</p> <p>Chicken Enchilada Casserole Beans & Bacon</p>	<p>26</p> <p>Breakfast Hotdish</p>	<p>27</p> <p>Chicken Ramen Noodle Dump</p>	<p>28</p> <p>Shrimp Basket Steak Fries Green Beans</p>
<p>31</p> <p>Beef & Bean Taco Bake Dirty Rice</p>	<p>ALL MEALS SERVED WITH DESSERT.</p>			

REMINDER! POTLUCK IS MARCH 3RD AT 6 PM



MARCH ACTIVITIES CALENDAR

Let's Get Social!

Check out this month's lineup of fun and friendship! From exciting events to everyday favorites, there's something for everyone. Don't miss out—mark your calendars and join the fun!

KEY - (SS) South Side

Monday	Tuesday	Wednesday	Thursday	Friday
3	4	5	6	7
Coffee - 9 A Walking - 9 A Aerobics - 10 A Lunch - 11:30 A Mexican Train - 12:30 P Open Games - 2 P Potluck - 6 P	Coffee - 9 A Bible Study - 10 A Lunch - 11:30 A Bingo - 12:30 P Open Games - 2 P	Coffee - 9 A Back to Balance - 10 A Yoga - 10:45 A Lunch - 11:30 A Hand & Foot - 12:30 P Prairie Port Seniors - 1 P Open Games - 2 P	Coffee - 9 A Tai-Chi - 9:30 A Lunch - 11:30 A Mexican Train - 12:30 P Pitch - 1 P Open Games - 2 P	Coffee - 9 A Cornhole - 9:30 A Aerobics (SS) - 10 A Lunch - 11:30 A Hand & Foot - 12:30 P Open Games - 2 P
10	11	12	13	14
Coffee - 9 A Walking - 9 A Craft Club - 9:30 A Aerobics - 10 A Lunch - 11:30 A Mexican Train - 12:30 P Painting W/ Sheila - 2 P Open Games - 2 P	Coffee - 9 A Bible Study - 10 A Lunch - 11:30 A BP Checks - 11:30 A Bingo - 12:30 P Open Games - 2 P	Coffee - 9 A Drawing Class - 9:15 A Back to Balance - 10 A Yoga - 10:45 A Lunch - 11:30 A Hand & Foot - 12:30 P Prairie Port Seniors - 1 P Open Games - 2 P	Coffee - 9 A Tai-Chi - 9:30 A Lunch - 11:30 A Mexican Train - 12:30 P Pitch - 1 P Open Games - 2 P	Coffee - 9 A Walking - 9 A Cornhole - 9:30 A Aerobics - 10 A Lunch - 11:30 A Lunch N' Learn - 11:45 A Hand & Foot - 12:30 P Open Games - 2 P
17	18	19	20	21
St. Patty's Breakfast - 8 A Coffee - 9 A Walking - 9 A Aerobics - 10 A Lunch - 11:30 A Mexican Train - 12:30 P Open Games - 2 P ALZ/Dementia - 5:30 P	Coffee - 9 A Coffee w/a Cop - 9:30 A Bible Study - 10 A Lunch - 11:30 A Bingo - 12:30 P Open Games - 2 P	Coffee - 9 A Drawing Class - 9:15 A Back to Balance - 10 A Yoga - 10:45 A Lunch - 11:30 A Hand & Foot - 12:30 P Prairie Port Seniors - 1 P Open Games - 2 P	Coffee - 9 A Tai-Chi - 9:30 A Lunch - 11:30 A Mexican Train - 12:30 P Pitch - 1 P Open Games - 2 P Membership Meeting - 6 P	Coffee - 9 A Cornhole - 9:30 A Aerobics (SS) - 10 A Lunch - 11:30 A Hand & Foot - 12:30 P Open Games - 2 P Dance - 6:30 P
24	25	26	27	28
Coffee - 9 A Walking - 9 A Aerobics - 10 A Lunch - 11:30 A Mexican Train - 12:30 P Open Games - 2 P	Coffee - 9 A Bible Study - 10 A Lunch - 11:30 A Bingo - 12:30 P Open Games - 2 P	Coffee - 9 A Drawing Class - 9:15 A Back to Balance - 10 A Yoga - 10:45 A Lunch - 11:30 A Hand & Foot - 12:30 P Prairie Port Seniors - 1 P Open Games - 2 P	Coffee - 9 A Tai-Chi - 9:30 A Lunch - 11:30 A Mexican Train - 12:30 P Pitch - 1 P Open Games - 2 P	Coffee - 9 A Walking - 9 A Cornhole - 9:30 A Aerobics - 10 A Lunch - 11:30 A Hand & Foot - 12:30 P Open Games - 2 P



KNOWLEDGE NUGGETS



- March is the third month of the year in the Julian and Gregorian calendars and has 31 days. It can symbolize new beginnings, renewal and rebirth. It can also represent the transition from winter to spring.
- March 1st is National Dadgum That's Good Day in the United States. The day celebrates everything that is exceptionally good and encourages people to share their enthusiasm for things they find delightful.
- On March 7, 1876, Alexander Graham Bell received the patent for the telephone. His invention would revolutionize communication and lead to the development of the telecommunications industry we know today.
- Johnny Appleseed Day: March 11th is Johnny Appleseed Day in the United States. Celebrated in honor of John Chapman, a folk hero who traveled across the country planting apple trees, this day promotes the planting of apple trees and recognizes their importance.
- On March 15, 1972, the iconic crime film "The Godfather" premiered in New York City. Directed by Francis Ford Coppola, the picture is renowned for its performances, notably Marlon Brando's portrayal of Vito Corleone.
- March 24, 1958, marks the day when Elvis Presley was inducted into the U.S. Army, serving as a regular soldier for two years until March 1960. Despite his fame, Elvis chose not to join special services, aiming to experience the army like an ordinary soldier.

BRADFORD MEMORIAL LIBRARY SERVICES

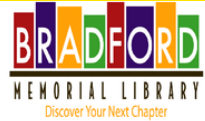

LARGE PRINT BOOKS

The Bradford Memorial Library brings in large print books for our members to check out. These books are kept in the office and are swapped out monthly, so there's always something new to read!

Can't Get Out of the House?

No problem! Butler County Library Outreach delivers books right to your door. If you're interested in receiving this service or know someone who would benefit, call Outreach at 316-321-3363 or email services@bradfordlibrary.info.

Issues with Your Eyesight?



El Dorado Senior Center presents TALKING BOOKS! This service, provided by the Library of Congress, National Library Service, and Kansas State Library, makes it possible for those with low vision or physical limitations to enjoy thousands of books and magazines for free!

Access Books Easily



- Use your phone, tablet, or computer to download audiobooks.
- Order books in braille.
- Get a FREE player to use at home with audiobooks mailed directly to you.

For more information or to start using Talking Books, call the ESC office at 316-321-0142 today!

SENIOR RESOURCES

THRIVE NOW AT THE SENIOR CENTER

We are excited to announce that Thrive has opened an office at the El Dorado Senior Center! Thrive is here to assist you with navigating online resources and completing forms for benefits such as: Social Security, Medicare, the Healthcare Marketplace, insurance, Medicaid, food assistance, disability, LIEAP and more.



Medicare Advantage Open Enrollment

Medicare Advantage Open enrollment is Jan. 1-**March 31**, during this time (only) people who ALREADY have an advantage plan can switch to another advantage plan or change back to original Medicare.

LIEAP Information

LIEAP application season opens early this year, from November 18th to **March 31st at 5 PM**. The program helps with electricity, home gas service, and wood burning. Applications can be printed or completed online.

Presumptive Eligibility Specialist Services

Helping parents (of children under 19), children, and pregnant individuals get immediate Medicaid coverage if eligible. This service might be useful for your family members.

Contact Information

To make an appointment with Andrea Campbell or Heather Patterson from Thrive, please call Andrea at 785-230-8809 or email her at Andrea@thriveallencounty.org or Heather 316-737-8170, heather@thriveallencounty.org. **PLEASE NOTE - Andrea and Heather will be out of the office March 3,4,5,10,12 for training.**

LEARN AND GROW WITH US

At the Center, we're here to help you reach your goals, keep learning, and stay independent. We offer various resources, classes, support groups, and seminars to support you.

Have something you'd like to learn? Want to get more familiar with your smartphone or computer? Share your ideas in the suggestion box or talk to Kristina directly!

Kristina can also help you find our new Senior Center Facebook page.

PREVENTING ELDER ABUSE

Elder abuse, neglect, and exploitation are serious issues that can affect anyone. It's crucial to address them promptly and compassionately.

If you or someone you know is experiencing any form of abuse, please reach out for help. Contact the Butler County Prevention of Elder Abuse at 1-800-279-3655 or 316-322-4254. Your call will be confidential, and support is available.

GRIEF SUPPORT GROUP

If you're seeking comfort and support through grief, join the Heartfelt Grief Support Group at Family Worship Center, 701 S. Atchison, El Dorado.

Meetings are held on the 2nd and 4th Tuesdays of each month from 6:30 to 7:30 PM. Please use the NW parking lot and entrance.

SENIOR RESOURCES

FOOT CARE CLINIC BY HERMES HEALTHCARE



Hermes HealthCare offers a convenient Foot Care Clinic right here at the senior center! To schedule an appointment for a pedicure, please call 316-260-4110. These services are covered by Medicare.

DATES:

March 7	March 21
May 9	May 23
July 11	July 25
September 12	September 26
November 14	

COMMODITIES DISTRIBUTION

We are pleased to announce the upcoming Commodities Distribution!

Distribution will take place on the **North Side** from **1 PM - 2 PM** on the following dates in 2025:

March 12	April 9
May 14	June 11
July 9	August 13
September 10	October 8
November 12	December 10

To submit an application for the Supplemental Food Program, please call the United Methodist Open Door Program office at (316) 267-0511.

Please pick up your commodities on the date to avoid any inconvenience. Timely pickup is crucial to ensure everyone receives their items smoothly.



EL DORADO ALZHEIMER'S SUPPORT GROUP



Presented By: Alzheimer's Association
Central & Western, KS

Who Joins a Support Group?

People of all ages and backgrounds join support groups. They seek support, knowledge about the disease, and ways to help each other with Alzheimer's challenges.

Why Join a Support Group?

Support groups are vital for both caregivers and patients. They provide education on managing Alzheimer/Dementia care, reducing stress, and improving the well-being of everyone involved. Research shows that support groups help caregivers cope better and keep patients living at home longer. Contrary to belief, groups are uplifting and a great place to find both support and laughter.

JOIN US!

3rd Monday Each Month
5:30 PM
El Dorado Senior Center
210 East 2nd
El Dorado, KS 67042

QUESTIONS?

Roxann Cool
roxann_cool@hotmail.com
or call the ESC
316-321-0142

March Crossword

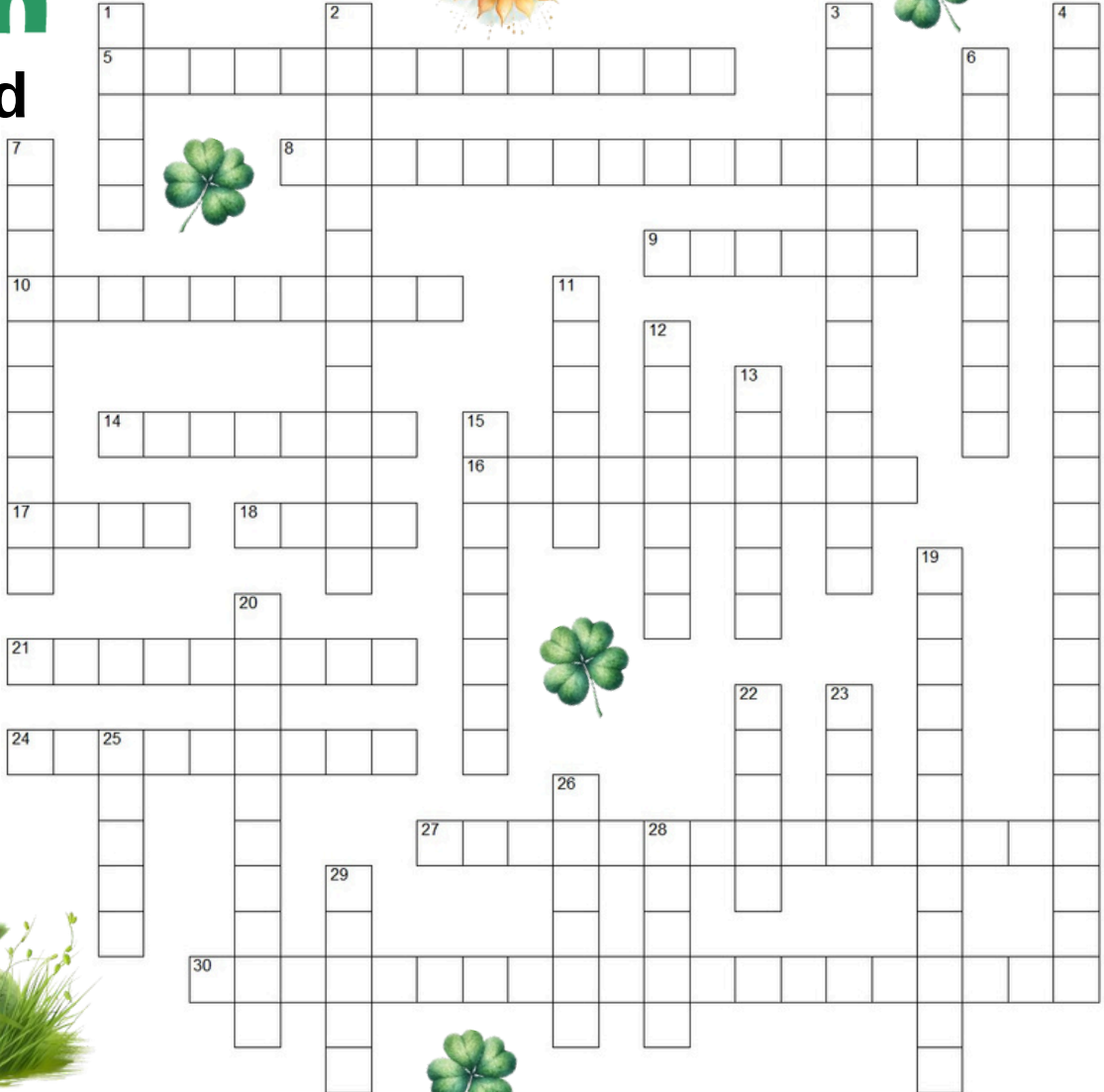

Across

- 5. Famous scientist born on March 14th, known for his theory of relativity
- 8. Time when clocks are moved forward an hour, occurring in March
- 9. Traditional color of Mardi Gras celebrations, which sometimes occur in March
- 10. Common March activity involving kites
- 14. Famous children's author born on March 2nd, known for "Green Eggs and Ham"
- 16. Birthstone associated with March
- 17. Common phrase related to March weather: "In like a ___ out like a lamb."
- 18. Common activity during March: filling out ___ brackets
- 21. Common March tradition: wearing ___ for good luck
- 24. Common March activity involving planting seeds
- 27. U.S. territory that celebrates its Transfer Day on March 31st
- 30. Holiday celebrated on March 2nd in Texas

Down

- 1. This month has the first day of spring
- 2. Famous Irish holiday celebrated on March 17th
- 3. Celestial event that marks the beginning of spring, occurring around March 20th
- 4. Day set aside for women's rights, observed on March 8th
- 6. Number of days in March
- 7. Popular sport often played in March
- 11. Holiday celebrated on March 21st, known as the Persian New Year
- 12. U.S. state that celebrates its statehood on March 4th
- 13. Term for the warmth that begins to return in March
- 15. Flower commonly associated with March
- 19. NCAA college basketball tournament held in March
- 20. Traditional meat served on St. Patrick's Day
- 22. Animal often associated with Easter, which sometimes falls in March
- 23. Ancient Roman festival celebrated at the end of March, honoring the god of war
- 25. Bird known for its return in March, signaling spring
- 26. Zodiac sign that begins in March
- 28. Color often associated with St. Patrick's Day
- 29. Popular spring break destination for many students

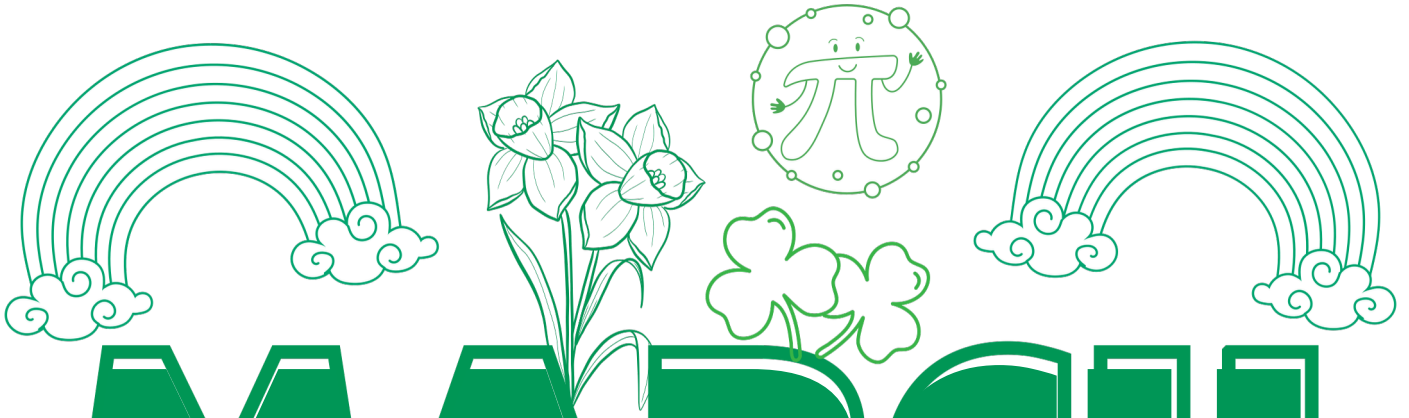

MARCH

WORD SEARCH

S	C	F	S	P	R	I	N	G	E	F	R	W	D	L	O	C	R	BIRDS
R	U	R	T	U	Y	M	I	P	A	A	B	K	X	T	N	A	A	CLOVER
L	P	B	P	F	L	S	A	R	G	I	D	R	A	M	S	Y	I	DAFFODIL
W	E	N	A	E	R	S	R	E	R	T	H	Y	W	R	T	K	N	DR SEUSS
S	D	P	T	B	R	C	E	D	E	R	V	X	A	L	A	M	B	FAT TUESDAY
H	G	L	R	R	E	S	S	I	E	A	F	D	F	E	W	M	O	FLOWER
A	W	W	I	E	T	P	B	D	N	R	E	H	F	K	F	L	W	GREEN
M	A	R	C	H	C	Y	W	E	N	E	S	E	L	I	H	C	S	LAMB
R	J	B	K	R	U	H	N	F	A	T	T	U	E	S	D	A	Y	LEPRECHAUN
O	H	R	S	Y	B	T	A	T	T	I	O	P	D	D	A	R	A	MARCH
C	E	E	D	L	I	L	N	U	E	T	C	Y	A	N	F	R	D	MARDI GRAS
K	E	P	A	N	R	R	O	L	N	I	L	J	Y	E	F	A	I	MARIO DAY
S	E	U	Y	D	S	Y	E	I	L	R	O	S	G	S	O	R	P	PI DAY
D	R	S	E	U	S	S	I	P	A	W	V	A	P	S	D	R	N	RAIN
W	F	M	A	R	I	O	D	A	Y	G	E	L	K	B	I	O	R	RAINBOWS
C	H	Y	A	D	J	O	H	D	N	D	R	E	W	O	L	F	R	SHAMROCK
																		SPRING
																		ST PATRICKS DAY
																		TULIP
																		WAFFLE DAY

SPOT THE DIFFERENCE

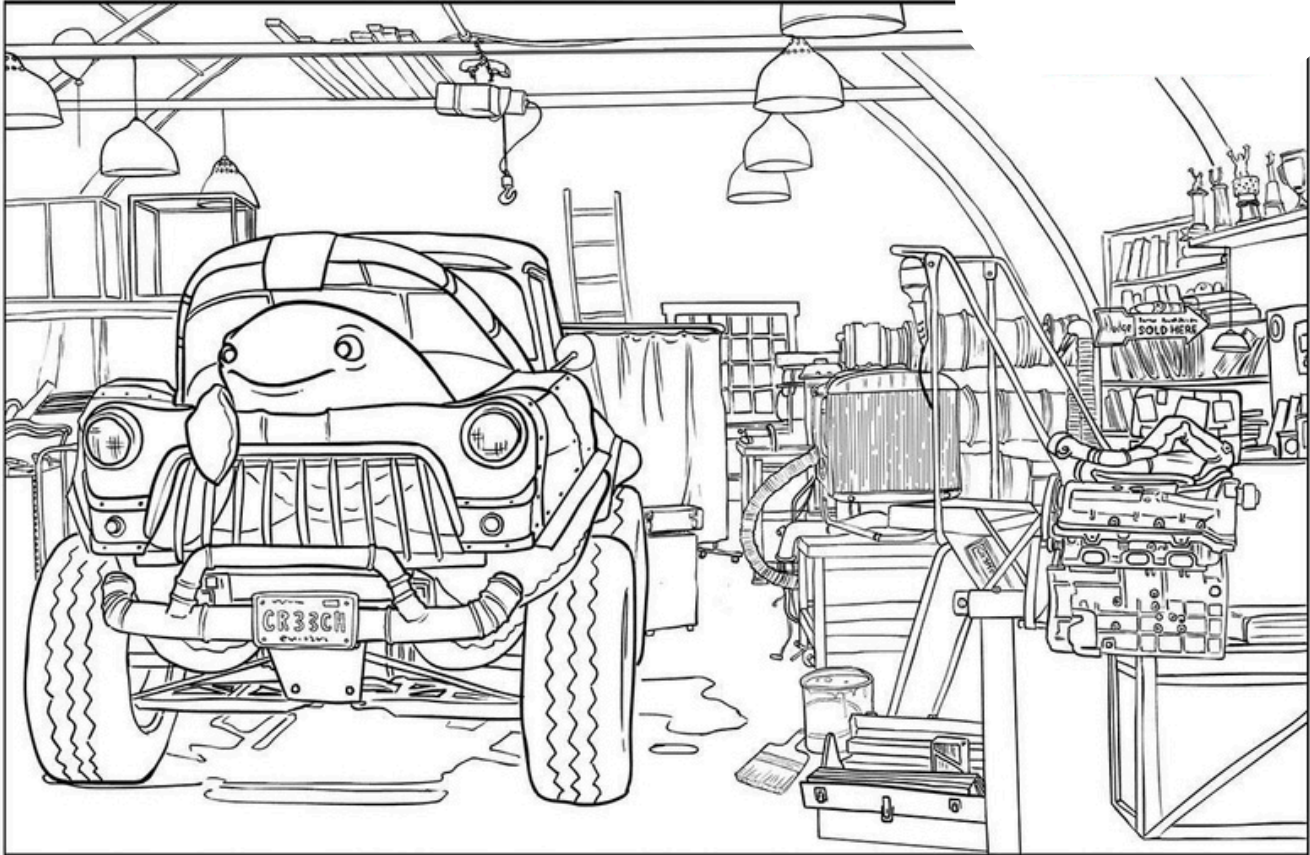

Can you find the 20 things that are different in these two pictures?

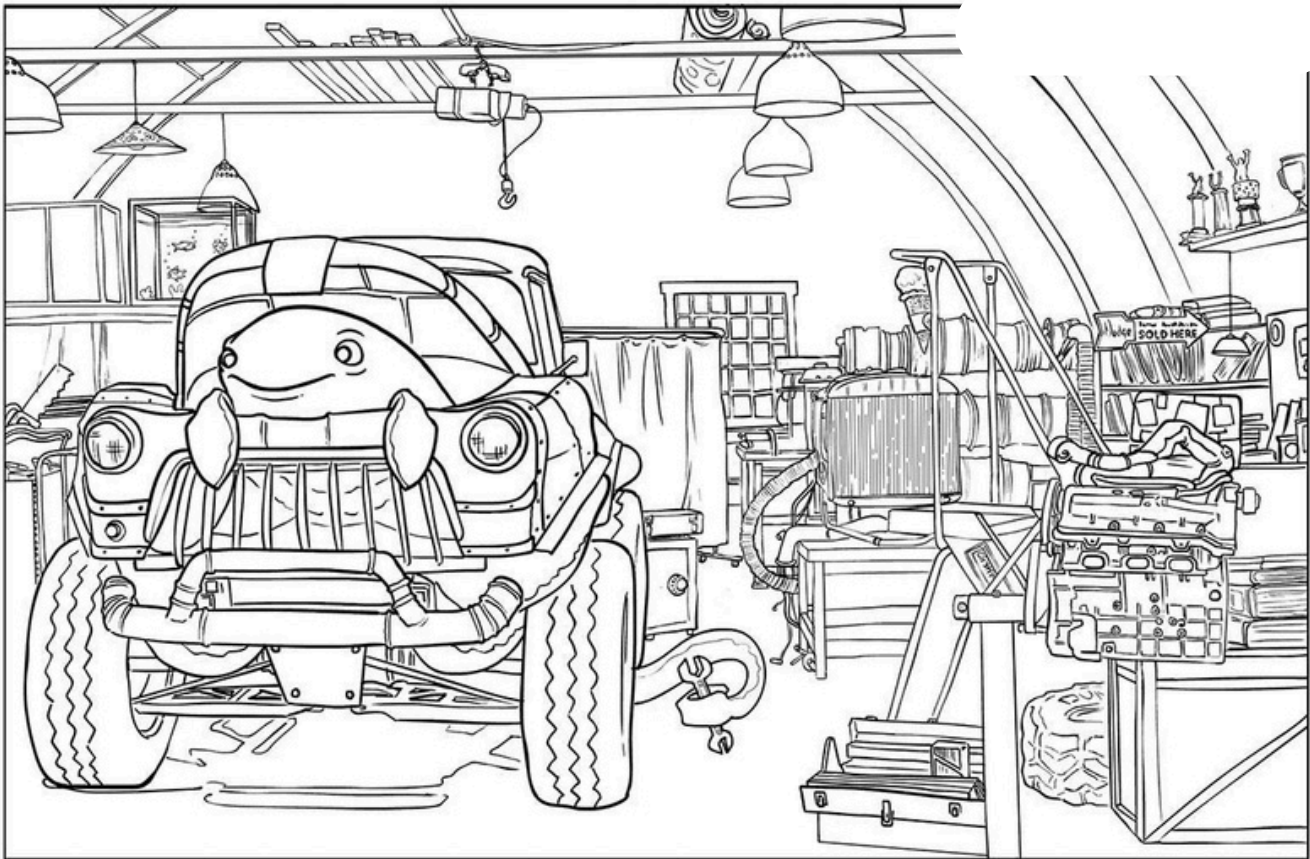

LEADERSHIP LENS: A NOTE FROM THE DIRECTOR

Hello, my fabulous friends!

Whew! We made it through all four of Kansas' winters—sometimes in the same day! It was tough not being open to see everyone, but boy, am I grateful for the sunshine we've already had and the warmer days ahead.



March is all about fresh starts. Winter fades into spring, and just like the seasons, it's the perfect time to shake things up and try something new at the center! And trust me, there will be plenty of new things to try—because we are kicking off fresh activities each month! Keep an eye on the calendar, because I've got some exciting things in the works that I know you're going to love.

Speaking of new, Fridays are about to get even better! We're adding more opportunities for learning over the lunch hour—think guest speakers, workshops, and hands-on experiences to keep things fun and engaging. So, grab your lunch, grab a friend, and join us for something different each week!

Now, let's talk about you. Don't see an activity on our schedule that you'd love to do? Come chat with me, and let's make it happen! Have a special talent you want to share? Let's spread the word! Thinking about volunteering in the office? (Because heavens knows I could use the help—ha!) I'd love to have you!

Got a fun fundraiser idea? Let me connect you with our committee! The more you are involved, the more vibrant and exciting our senior center becomes. YOU bring this place to life, and I am beyond grateful to be part of it every day.

So let's embrace some new beginnings—whether it's joining an aerobics group, trying chair tai chi, learning how to draw, or stepping into a leadership role. I challenge you to try something new. After all, old(ish) dogs can learn new tricks!

Here's to a fantastic spring full of new adventures!

See you at the center!

Your Director ❤️